



MIXMOR

MIXMOR MIXERS

FOR EVERY INDUSTRY

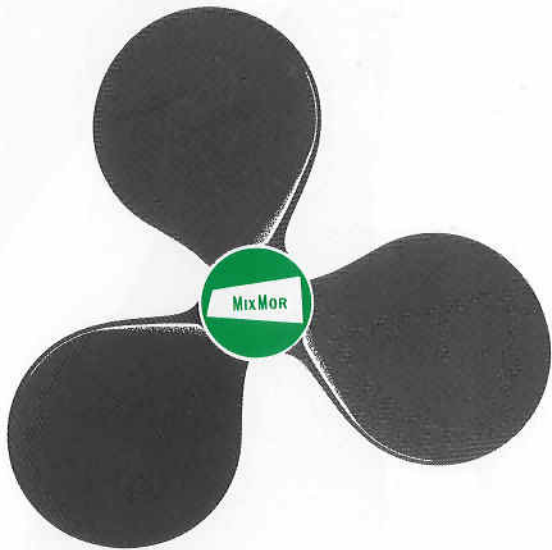

TABLE OF CONTENTS

PORTABLE MIXERS

Direct drive, electric or air	4
Gear drive, electric or air	5

TOP ENTRY MIXERS

Flange mount, direct or gear drive	6
Plate mount, direct or gear drive	7
Shaft seals	8

AIR MOTOR PERFORMANCE GRAPHS	9
------------------------------------	---

LABORATORY MIXERS	10
-------------------------	----

POSITIONING TIPS	10-11
------------------------	-------

PROPELLER DATA	11
----------------------	----

VARIABLE SPEED DRIVE	12-13
----------------------------	-------

MIXMOR THROUGH THE YEARS	14
--------------------------------	----

MIXERS FOR EVERY INDUSTRIAL APPLICATION	15
---	----

PERFORMANCE IS OUR CREED

Industrial mixers can be designed and built to any level of quality, to sell at any price. But only the uninitiated or impractical buyer will consign the fate of his end product to an "economy" mixer that is inadequate for the job.

At MIXMOR, we understand the economics of mixing. We know that the user's profits are adversely affected when mixer problems lead to substandard products or production downtime.

That is why we build assured performance into every MIXMOR unit. The fact that they are still competitively priced is due, not to compromises in quality and capability, but to design simplicity and volume production. Here are just a few of the features that contribute to MIXMOR reliability:

DEPENDABLE MOTORS. For top entry propeller or portable mixers, all electric motors are either totally enclosed

or explosion-proof, single or three phase, NEMA Style C footless. Side entry and turbine units use standard foot mounted motors with choice of enclosure. All motors are standard models of well-known manufacturers and may be replaced from shelf stock.

LASTING LUBRICATION. Motor and shaft bearings are grease sealed and require no lubrication for the life of the bearing. Propeller mixer gear housings are grease packed before shipment and need no relubrication for one year at temperatures up to 250°F.

TRUE-RUNNING SHAFTS. Shafts are precision-ground and polished, and are carefully straightened under test to eliminate runout that could shorten bearing life.

EFFICIENT PROPELLERS. Propellers are square pitch and sized to suit the job. All propellers are statically balanced for vibration-free operation.

MIXMOR

PORTABLE MIXERS

DIRECT DRIVE. The mixer drive assembly components are factory aligned and tested, and are shipped as a package for jobsite mounting. The drive assembly includes an electric or air motor with prelubricated ball bearings. The motor has a NEMA Style C footless mounting for direct connection to the quill housing. Because of the direct drive design, full motor speed is transmitted to yield mixer shaft output speed of 1750 rpm for 1/4 thru 3/4 horsepower and 1150 rpm for 1 thru 5 horsepower.

The lower chuck component consists of an aluminum housing containing a widely spaced, prelubricated, double-sealed ball bearing to provide outboard support of the chuck shaft, which is subject to mixing stresses.

The swivel ball-and-socket mixer mounting arrangement attached to the quill housing is designed to allow 360° rotation on the horizontal plane and 90° on the vertical plane so proper positioning of the shaft and propellers can be achieved at the jobsite. A single or double (depending on hp) aluminum hand-wheel assembly is provided for mounting the bronze clamp on the tank wall.

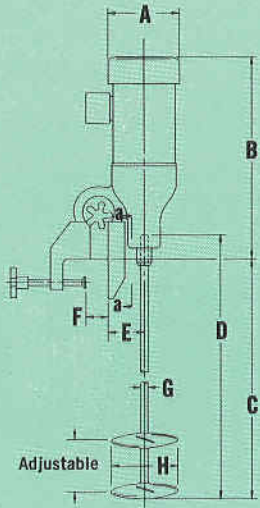

DIRECT DRIVE - ELECTRIC

MODEL	HP	DIMENSIONS, INCHES								H DUAL PROP. DIA.	WEIGHT, POUNDS*
		A	B	C	D	E	F	G			
D-14	1/4	6	17	35	36	3	3	5/8	3 1/2	34	
D-13	1/3	6	17	35	36	3	3	5/8	4	35	
D-12	1/2	7	20	46	48	3 3/4	3 3/4	5/8	4 1/2	52	
D-34	3/4	7	21	46	48	3 3/4	3 3/4	5/8	5	55	
D-11	1	7	21	58	60	3 3/4	3 3/4	7/8	6	85	
D-15	1 1/2	9	21	58	60	3 3/4	3 3/4	7/8	6 1/2	112	
D-2	2	9	23	58	60	3 3/4	3 3/4	7/8	7	123	
D-3	3	11	24	58	60	3 3/4	3 3/4	7/8	7 1/2	159	
D-5	5	11	25	58	60	3 3/4	3 3/4	7/8	7 1/2	182	

*Weight may vary with motor specifications.

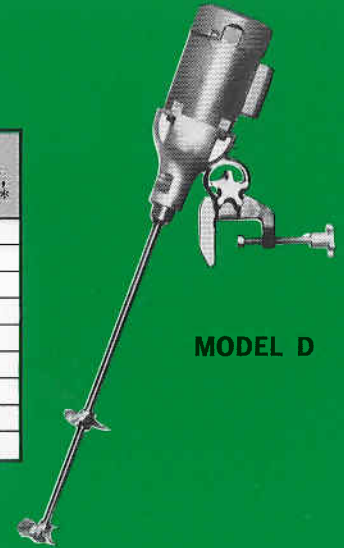

MODEL D

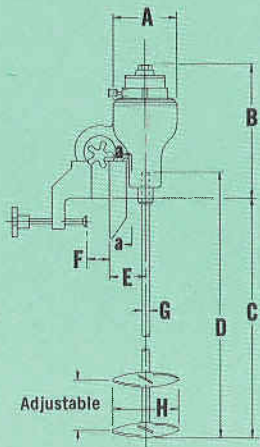

DIRECT DRIVE - AIR

MODEL	HP	DIMENSIONS, INCHES								H DUAL PROP. DIA.	WEIGHT, POUNDS
		A	B	C	D	E	F	G			
DA-13	1/3	6 1/2	12	35	36	3	3	5/8	4	30	
DA-11	1	6 1/2	12	46	48	3	3	5/8	6	36	
DA-2	2	6 1/2	16 1/2	58	60	3 3/4	3 3/4	7/8	6 1/2	70	
DA-4	4	6 1/2	18	58	60	3 3/4	3 3/4	7/8	7 1/2	80	

Dimensions are approximate. Certified dimensional prints furnished upon request.

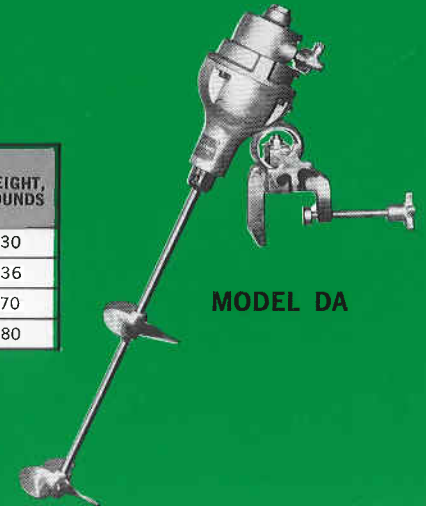

MODEL DA

SECTION a-a CLAMP FACE

Dimensions,
Inches

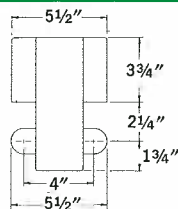

AS FURNISHED FOR:
Model D - 1 through 5 hp.
DA-2
DA-4
Model G - 1/2 through 5 hp.
Model GA - 1, 2, & 4

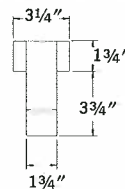

AS FURNISHED FOR:
Model D - 1/4 and 1/3 hp.
Model DA - 1/3 and 1 hp.

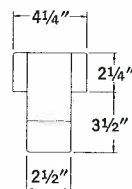

AS FURNISHED FOR:
Model G - 1/4 and 1/3 hp.
Model GA - 1/3 hp only.
Model D - 1/2 and 3/4 hp.

GEAR DRIVE. The mixer drive assembly components are factory aligned and tested, and shipped as a package for jobsite mounting. The drive assembly includes an electric or air motor with prelubricated ball bearings. The motor has a NEMA Style C footless mounting for direct connection to the gear reducer housing.

The single reduction gear reducer component consists of a factory grease-packed aluminum housing containing a pinion gear (mounted on the extended motor shaft) and a driven gear (mounted on a hollow quill output shaft). Mixer shaft output speed is 420 rpm. The gear reducer housing is machine-fitted to the lower quill-supporting housing.

The lower quill component consists of a cast aluminum housing containing widely spaced, prelubricated, double-sealed ball bearings to provide independent support of the hollow quill output shaft, which is subject to mixing stresses. The hollow chuck is assembled to the solid mixer shaft at the jobsite.

The swivel ball-and-socket mixer mounting arrangement attached to the gear reducer housing is designed to allow 360° rotation on the horizontal plane and 90° on the vertical plane so that proper positioning of the shaft and propellers can be achieved at the jobsite. A single or double (depending on hp) handwheel is provided for mounting the bronze clamp on the tank wall.



MODEL G

GEAR DRIVE – ELECTRIC

MODEL	HP	DIMENSIONS, INCHES						G DUAL PROP. DIA.	WEIGHT, POUNDS*
		A	B	C	D	E	F		
G-14	1/4	18	32	36	5/8	5 5/8	3 3/8	7	45
G-13	1/3	18	32	36	5/8	5 5/8	3 3/8	8	47
G-12	1/2	20	46	48	7/8	6 3/8	3 3/4	10	95
G-34	3/4	21	46	48	7/8	6 3/8	3 3/4	11	100
G-11	1	21	58	60	7/8	6 3/8	3 3/4	12	105
G-15	1 1/2	22	58	60	7/8	6 3/8	3 3/4	13	109
G-2	2	22	58	60	7/8	6 3/8	3 3/4	14	120
G-3	3	24	58	60	7/8	6 3/8	3 3/4	15	140
G-5	5	25	58	60	7/8	6 3/8	3 3/4	15	165

*Weight may vary with motor specifications.

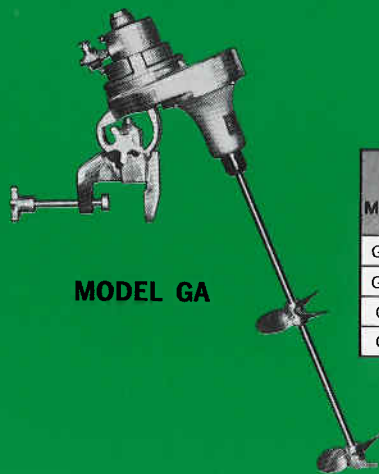
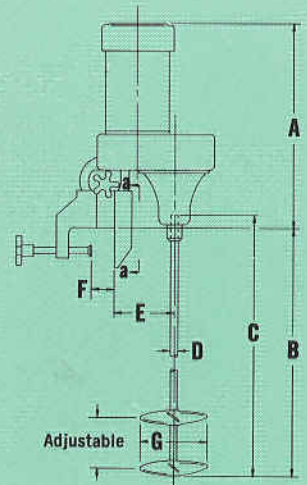

MODEL GA

GEAR DRIVE – AIR

MODEL	HP	DIMENSIONS, INCHES						G DUAL PROP. DIA.	WEIGHT, POUNDS
		A	B	C	D	E	F		
GA-13	1/3	14	32	36	5/8	5 5/8	3 3/8	8	45
GA-11	1	16	56	60	7/8	6 3/8	3 3/4	12	80
GA-2	2	16 1/2	58	60	7/8	6 3/8	3 3/4	14	95
GA-4	4	18	58	60	7/8	6 3/8	3 3/4	15	105

Dimensions are approximate. Certified dimensional prints furnished upon request.

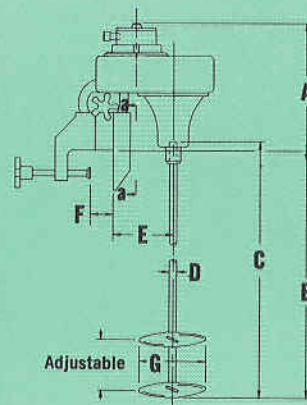

CUP BASE TO REPLACE CLAMP

Optional.
Dimensions
in Inches.

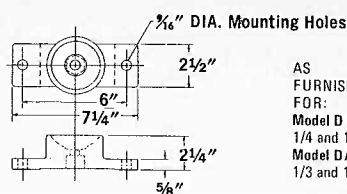

AS
FURNISHED
FOR:
Model D –
1/4 and 1/3 hp.
Model DA –
1/3 and 1 hp.

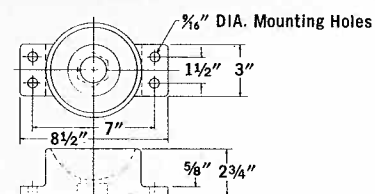

AS FURNISHED
FOR:
Model D –
1/2 through 5 hp.
DA-2
DA-4
Model G –
all units.
Model GA –
all units.



TOP ENTRY MIXERS

PROPELLER TYPE

FLANGE MOUNTED. These mixers mount permanently on flanges of pressure or vacuum tanks and are used for all viscosities. A conventional chemical pump stuffing box is provided for maintaining vacuum or pressure. A lantern

ring permits addition of lubricant or sealing fluid. These mixers are standard with forged steel flange, shaft and two propellers; also available with stainless steel flange facing, stuffing box, shaft and propellers.

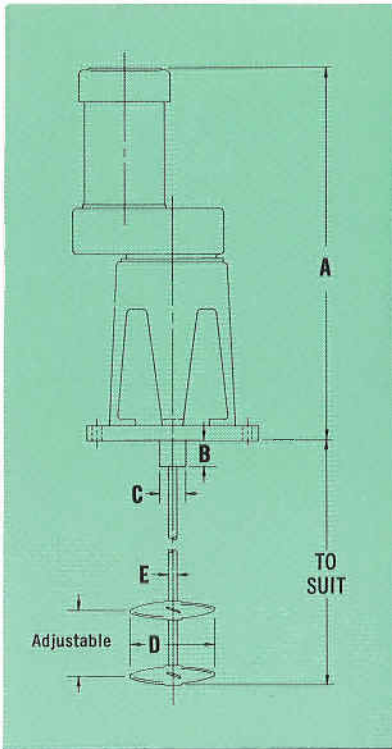

GEAR DRIVE – FLANGE

420 R.P.M. — ALL UNITS

MODEL	HP	DIMENSIONS, INCHES					STD. FLANGE, 150# SERIES	WEIGHT, POUNDS
		A	B	C	D DUAL PROP. DIA.	E		
FG-14	1/4	22	2 1/4	2 1/2	7	5/8	5	69
FG-13	1/3	23	2 1/4	2 1/2	8	5/8	5	71
FG-12	1/2	28	3	3 1/4	10	1 1/4	8	150
FG-34	3/4	29	3	3 1/4	11	1 1/4	8	153
FG-11	1	29	3	3 1/4	12	1 1/4	8	160
FG-15	1 1/2	30	3	3 1/4	13	1 1/4	8	165
FG-2	2	30	3	3 1/4	14	1 1/4	8	172
FG-3	3	31	3	3 1/4	15	1 1/4	8	203
FG-5	5	32	3	3 1/4	15	1 1/4	8	215

FIG. 762: Rated 150 psig @ 420 rpm. Seven rings of packing, a lantern ring for distribution of lubricant, and a packing gland for adjusting packing.

FIG. 763: Rated 25 psig @ 420 rpm. Two rings of packing and a packing gland for adjusting packing.

FIG. 855: Double mechanical seal, rated 450° F., 175 psi. Seal housing is tapped for inlet and outlet of lubricant. When higher pressures are encountered, it can be furnished with hydraulically balanced sealing faces.



MODEL FG

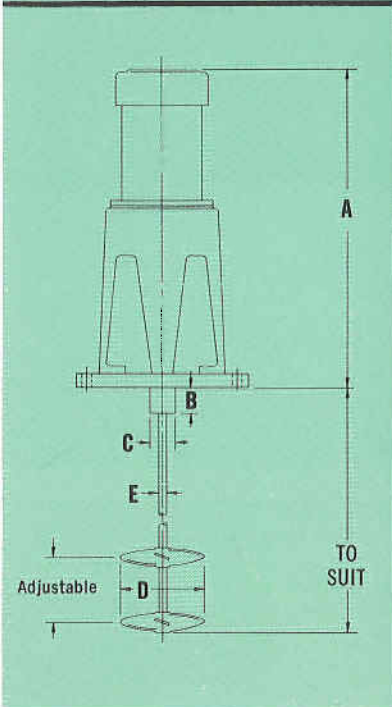

DIRECT DRIVE – FLANGE

1/4 THROUGH 3/4 H.P. — 1750 R.P.M.

1 THROUGH 5 H.P. — 1160 R.P.M.

MODEL	HP	DIMENSIONS, INCHES					STD. FLANGE, 150# SERIES	WEIGHT, POUNDS
		A	B	C	D DUAL PROP. DIA.	E		
FD-14	1/4	18	2 1/4	2 1/2	3 1/2	5/8	5	60
FD-13	1/3	19	2 1/4	2 1/2	4	5/8	5	63
FD-12	1/2	21	2 1/4	2 1/2	4 1/2	7/8	8	82
FD-34	3/4	21	2 1/4	2 1/2	5	7/8	8	85
FD-11	1	22	3	3 1/4	6	1 1/4	8	131
FD-15	1 1/2	22	3	3 1/4	6 1/2	1 1/4	8	158
FD-2	2	24	3	3 1/4	7	1 1/4	8	169
FD-3	3	26	3	3 1/4	7 1/2	1 1/4	8	205
FD-5	5	27	3	3 1/4	7 1/2	1 1/4	8	228

Available as Figure 762, 763 or 855. See descriptions above.

Dimensions are approximate.
Certified dimensional prints furnished upon request.

MODELS FG, FD, OG & OD ALSO AVAILABLE WITH AIR MOTORS.



MODEL FD

PLATE MOUNTED. These top entry mixers are for use on an open tank, where no stuffing box is required to maintain vacuum or pressure. They are identical in all respects to the flange-mounted mixers except that the flange is replaced by a rugged square aluminum plate with pre-

drilled bolt holes for easy mounting.

They may be bolted or clamped to any shop-made support above the tank, or installed on an angle bracket made by MIXMOR that assures correct position of the shaft and propellers in the tank.



MODEL OG

GEAR DRIVE — PLATE

420 R.P.M. — ALL UNITS

MODEL	HP	DIMENSIONS, INCHES			WEIGHT, POUNDS
		C	D	E DUAL PROP. DIA.	
OG-14	1/4	22	5/8	7	60
OG-13	1/3	23	5/8	8	63
OG-12	1/2	28	1 1/4	10	119
OG-34	3/4	29	1 1/4	11	121
OG-11	1	29	1 1/4	12	129
OG-15	1 1/2	30	1 1/4	13	134
OG-2	2	30	1 1/4	14	141
OG-3	3	31	1 1/4	15	172
OG-5	5	32	1 1/4	15	184

CHOICE OF MOUNTING FOR MODELS OG AND OD (REFER TO MODEL OG DRAWING FOR LOCATION)

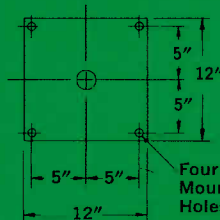

SECTION A-A FLAT PLATE

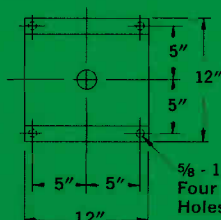

SECTION B-B ANGLE RISER

DIRECT DRIVE — PLATE

1/4 THROUGH 3/4 H.P. — 1750 R.P.M.

1 THROUGH 5 H.P. — 1160 R.P.M.

Dimensions are approximate. Certified dimensional prints furnished upon request.

MODEL	HP	DIMENSIONS, INCHES			WEIGHT, POUNDS
		A	B	C DUAL PROP. DIA.	
OD-14	1/4	18	5/8	3 1/2	53
OD-13	1/3	19	5/8	4	55
OD-12	1/2	21	7/8	4 1/2	63
OD-34	3/4	21	7/8	5	66
OD-11	1	22	1 1/4	6	100
OD-15	1 1/2	22	1 1/4	6 1/2	137
OD-2	2	24	1 1/4	7	148
OD-3	3	26	1 1/4	7 1/2	184
OD-5	5	27	1 1/4	7 1/2	207

